

AUTOPULSE IQ-318 Agent Releasing Control Panel

General

The AUTOPULSE IQ-318 Agent Releasing Control Panel is designed with modularity and easy system planning. The AUTOPULSE IQ-318 can be configured with just a few devices for small building applications or for a large campus or high-rise application. Simply add additional peripheral equipment to suit the application.

Note: Unless called out with a version-specific “C” or “E” at the end of the part number, “IQ-318” refers to models IQ-318, IQ-318C, and IQ-318E.

Features

- Certified for seismic applications when used with the appropriate seismic mounting kit.
- Approved for Marine applications when used with listed compatible equipment.
- One isolated intelligent Signaling Line Circuit (SLC) Style 4, 6, or 7.
- Up to 159 detectors (any mix of ion, photo, thermal, or multi-sensor) and 159 modules (NO manual stations, two wire smoke, notification, or relay). 318 devices maximum.
- A 2x40 character display.
- Four Notification Appliance Circuits (NAC) providing 1.5 Amps each with built-in Class A/B wiring options. Selectable System Sensor, Wheelock, or Gentex strobe synchronization.
- Built-in Alarm, Trouble, and Supervisory relays.
- VeriFire® Tools online or offline programming utility. Upload/Download, save, store, check, compare, and simulate panel databases. Upgrade panel firmware.
- Autoprogramming and Walk Test reports.
- Optional universal 318-point DACT.
- Up to 32 remote annunciators can be added on EIA-485 bus.
- EIA-485 annunciators, including custom graphics.
- EIA-232 port for printing or PC connection.
- History file with 800-event capacity in nonvolatile memory, plus separate 200-event alarm-only file.
- Alarm Verification selection per point, with tally.
- Positive Alarm Sequence (PAS) Presignal.
- Silence inhibit and Auto Silence timer options.
- March time / temporal / California two-stage coding / strobe synchronization.
- Field-programmable on panel or on PC, with VeriFire Tools program check, compare, simulate.
- Full QWERTY keypad.



007704

- Battery charger supports 18-200 AH batteries.
- Non-alarm points for lower priority functions.
- Remote ACK/Signal Silence/System Reset/Drill via monitor modules.
- Automatic time control functions, with holiday exceptions.
- Extensive, built-in transient protection.
- Powerful Boolean logic equations.
- USB port for PC connection.

FlashScan® intelligent features:

- Poll 318 devices in less than two seconds.
- Activate up to 159 outputs in less than five seconds.
- Multicolor LEDs blink device address during Walk Test.
- Fully digital, high-precision protocol.
- Manual sensitivity adjustment — nine levels.
- Pre-alarm ONYX intelligent sensing — nine levels.
- Day/Night automatic sensitivity adjustment.
- Sensitivity windows:
 - Ion** – 0.5 to 2.5%/foot obscuration.
 - Photo** – 0.5 to 2.35%/foot obscuration.
 - Laser (VIEW®)** – 0.02 to 2.0%/foot obscuration.
 - Acclimate Plus™** – 0.5 to 4.0%/foot obscuration.
- Drift compensation.
- Degraded mode — in the unlikely event that the CPU-318 microprocessor fails, FlashScan detectors revert to degraded operation and can activate the CPU-318 NAC circuits and alarm relay. Each of the four built-in panel circuits includes a Disable/Enable switch for this feature.
- Multi-detector algorithm involves nearby detectors in alarm decision.
- Automatic detector sensitivity testing (NFPA 72 compliant).
- Maintenance alert (two levels).
- Self-optimizing pre-alarm.

Features (Continued)

VIEW (Very Intelligent Early Warning) smoke detection technology:

- Revolutionary spot laser design.
- Advanced intelligent sensing algorithms differentiate between smoke and non-smoke signals.
- Addressable operation pinpoints the fire location.
- No moving parts to fail or filters to change.
- Early warning performance comparable to the best aspiration systems at a fraction of the lifetime cost.

Acclimate Plus low-profile intelligent multi-sensor:

- Detector automatically adjusts sensitivity levels without operator intervention or programming. Sensitivity increases with heat.
- Microprocessor-based technology; combination photo and thermal technology.
- FlashScan or classic mode compatible with NFS2-636, NFS-318.
- Low-temperature warning signal at $40\text{ }^{\circ}\text{F} \pm 5\text{ }^{\circ}\text{F}$ ($4\text{ }^{\circ}\text{C} \pm 3\text{ }^{\circ}\text{C}$).

Releasing features:

- Ten independent hazards
- Sophisticated cross-zone (three options)
- Delay timer and Discharge timers (adjustable)
- Abort (four options)
- Low Pressure CO₂ Listed

High-efficiency offline switching 3.0 amp power supply (6.0 A in alarm):

- 120 VAC (IQ-318, IQ-318C) or 240 VAC (IQ-318E)
- Displays battery current/voltage on panel (with display)

FlashScan Exclusive New World-Leading Detector Protocol

At the heart of the AUTOPULSE IQ-318 is a set of detection devices and device protocol — FlashScan. Flash-Scan is an all-digital protocol that gives superior precision and high noise immunity.

In addition to providing quick identification of an active input device, this new protocol can also activate many output devices in a fraction of the time required by competitive protocols.

This high speed also allows the AUTOPULSE IQ-318 to have the largest device per loop capacity in the industry — 318 points — yet every input and output device is sampled in less than two seconds. The microprocessor-based FlashScan detectors have bicolor LEDs that can be coded to provide diagnostic information, such as device address during Walk Test.

Intelligent Sensing

Intelligent sensing is a set of software algorithms that provides the AUTOPULSE IQ-318 with industry-leading smoke detection capability. These complex algorithms require many calculations on each reading of each detector, and are made possible by the very high-speed microcomputer used by the AUTOPULSE IQ-318.

Drift Compensation and Smoothing: Drift compensation allows the detector to retain its original ability to detect actual smoke, and resist false alarms, even as dirt accumulates. It reduces maintenance requirements by allowing the system to automatically perform the periodic sensitivity measurements required by NFPA 72. Smoothing filters are also provided by software to remove transient noise signals, such as those caused by electrical interference.

Maintenance Warnings: When the drift compensation performed for a detector reaches a certain level, the performance of the detector may be compromised, and special warnings are given. There are three warning levels: (1) Low Chamber value, usually indicative of a hardware problem in the detector; (2) Maintenance Alert, indicative of dust accumulation that is near but below the allowed limit; (3) Maintenance Urgent, indicative of dust accumulation above the allowed limit.

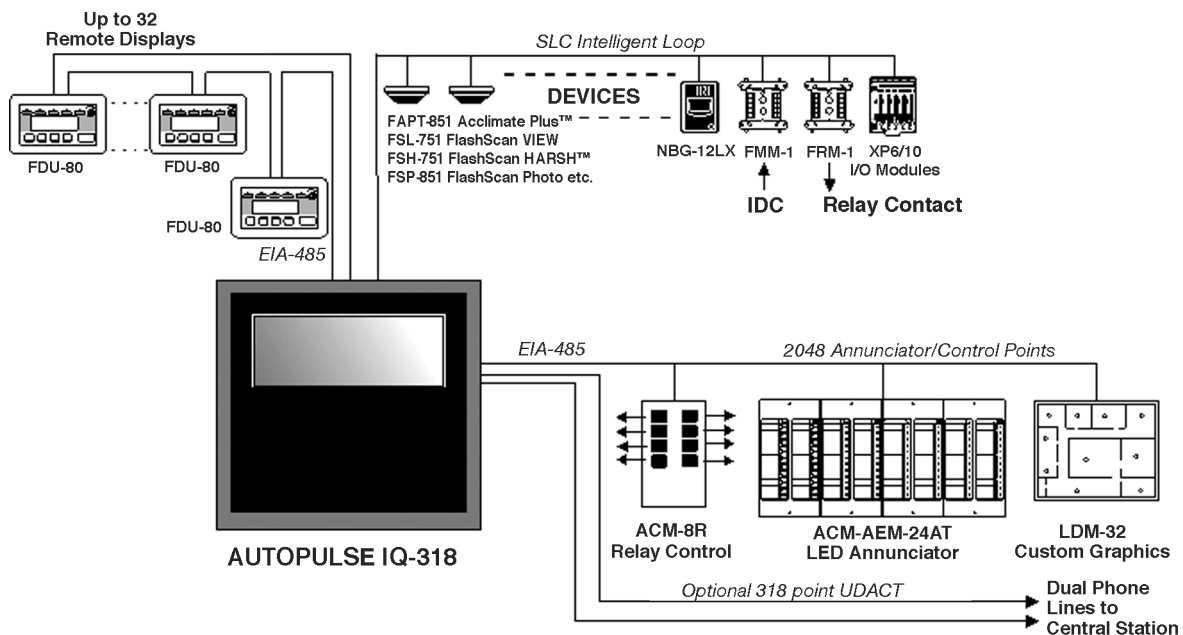

Sensitivity Adjust: Nine sensitivity levels are provided for alarm detection. These levels can be set manually, or can change automatically between day and night. Nine levels of pre-alarm sensitivity can also be selected, based on predetermined levels of alarm. Pre-alarm operation can be latching or self-restoring, and can be used to activate special control functions.

Self-Optimizing Pre-Alarm: Each detector may be set for "Self-Optimizing" pre-alarm. In this special mode, the detector "learns" its normal environment, measuring the peak analog readings over a long period of time, and setting the pre-alarm level just above these normal peaks.

Cooperating Multi-Detector Sensing: A patented feature of intelligent sensing is the ability of a smoke sensor to consider readings from nearby sensors in making alarm or pre-alarm decisions. Without statistical sacrifice in the ability to resist false alarms, it allows a sensor to increase its sensitivity to actual smoke by a factor of almost two to one.

Field Programming Options

Autoprogram is a timesaving feature of the AUTOPULSE IQ-318. It is a special software routine that allows the AUTOPULSE IQ-318 to "learn" what devices are physically connected and automatically load them in the program with default values for all parameters. Requiring less than one minute to run, this routine allows the user to have almost immediate fire protection in a new installation, even if only a portion of the detectors are installed.

Keypad Program Edit (with KDM-R2): The AUTOPULSE IQ-318, like all AUTOPULSE intelligent panels, has the exclusive feature of program creation and editing capability from the front panel keypad, **while continuing to provide fire protection.** The architecture of the AUTOPULSE IQ-318 software is such that each point entry carries its own program, including control-by-event links to other points. This allows the program to be entered with independent per-point segments, while the AUTOPULSE IQ-318 simultaneously monitors other (already installed) points for alarm conditions.

VeriFire Tools is an online and offline programming and test utility that can greatly reduce installation programming time, and increase confidence in the site-specific software. It is Windows®-based and provides technologically advanced capabilities to aid the installer. The installer may create the entire program for the AUTOPULSE IQ-318 in the comfort of the office, test it, store a backup file, then bring it to the site and download from a laptop into the panel.

CPU-318 Board Diagram

TB10: DC Power (24 VDC, power-limited); Non-Resettable, Resettable.
TB11: EIA-485 Connection (supervised); Terminal Mode, ACS Mode.

TB12: EIA-232 Connection; Printer, PC/Terminal (CRT).
J1: Network/Service Connection (NUP), power-limited, supervised.

J2: USB A VeriFire Tools Connection.
J3: USB B VeriFire Tools Connection.
TB13: SLC Loop #1 (supervised, power-limited).

JP1: Ground Fault Jumper (SLC #1).
JP2: Cut for 200 mA operation.
LED10: SLC Loop Ground Fault.

All NAC circuits are power-limited, supervised.

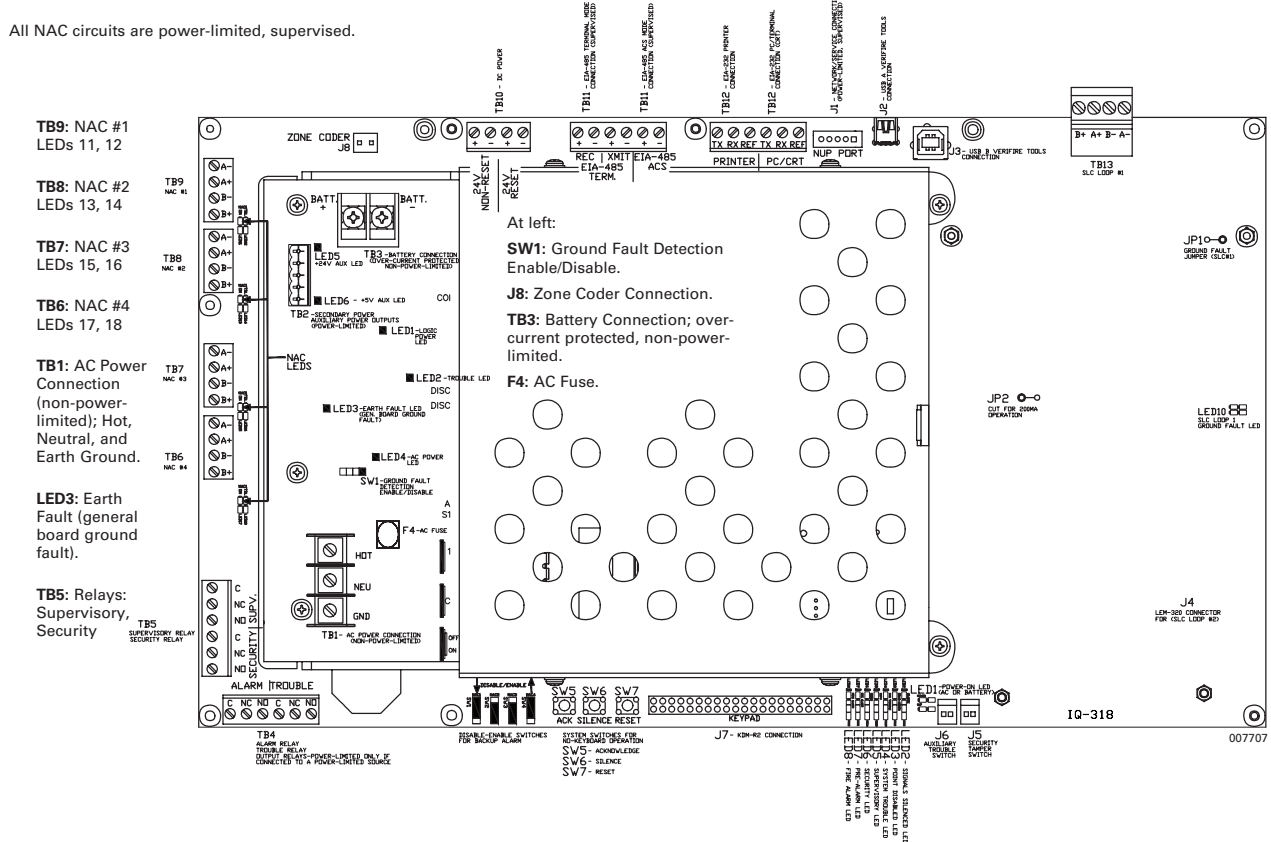

TB4: Alarm Relay, Trouble Relay. Output relays; power-limited only if connected to a power-limited source.

SW1, SW2, SW3, SW4: Disable-Enable switches for Backup Alarm, NACs 1-4 respectively.

System switches, "No Keyboard Operation":
SW5: Acknowledge
SW6: Silence

SW7: Reset
J7: KDM-R2 Connection
LED1: Power On (AC or battery)

LED2: Signals Silenced
LED3: Point Disabled
LED4: System Trouble
LED5: Supervisory
LED6: Security

LED7: Pre-Alarm
LED8: Fire Alarm
J4: LEM-320 Connector for SLC Loop #2

J5: Security Tamper Switch
J6: Auxiliary Trouble Input

AUTOPROGRAM PLEASE WAIT

L1:80 DETS, 15 MODS
BELLS: 04

Autoprogram Function

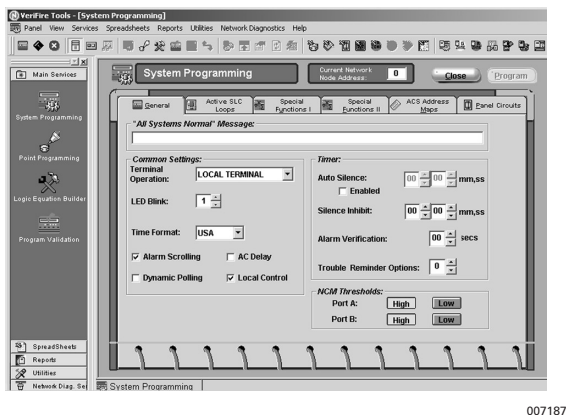

VeriFire Tools System Programming Screen

Placement of Equipment in Chassis and Cabinet

The following guidelines outline the AUTOPULSE IQ-318 flexible system design.

Wiring: When designing the cabinet layout, consider separation of power-limited and non-power-limited wiring as discussed in the AUTOPULSE IQ-318 Installation Manual.

It is critical that all mounting holes of the AUTOPULSE IQ-318 are secured with a screw or standoff to ensure continuity of Earth Ground.

Equipment Placement in AUTOPULSE IQ-318 Chassis

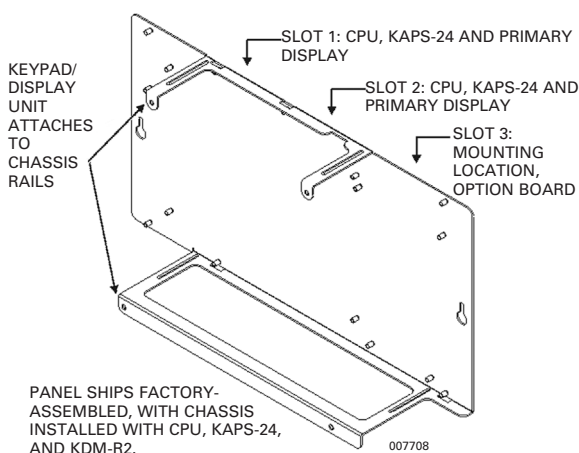

KDM-R2 Controls and Indicators

Program Keypad: QWERTY type (keyboard layout).

12 LED Indicators: Power; Fire Alarm; Pre-Alarm; Security; Supervisory; System Trouble; Signals Silenced; Points Disabled; Control Active; Abort; Pre-Discharge; Discharge.

Membrane Switch Controls: Acknowledge/Scroll Display; Signal Silence; Drill; System Reset; Lamp Test.

LCD Display: 80 characters (2 x 40) with long-life LED backlight.

Configuration Guidelines

The AUTOPULSE IQ-318 system ships assembled; description and some options follow.

AUTOPULSE IQ-318: The standard, factory-assembled AUTOPULSE IQ-318 panel includes the following components: one CPU-318 control panel mounted on chassis (120 V operation – ships with grounding cable, battery interconnect cables, and document kit); one KAPS-24 integral power supply mounted to the CPU-318; one primary display KDM-R2 keypad/display; and one cabinet for surface or semi-flush mounting. Purchase batteries separately. One or two option boards may be mounted inside the AUTOPULSE IQ-318 cabinet; additional option boards can be utilized in remote cabinets.

AUTOPULSE IQ-318C: Based on AUTOPULSE IQ-318 above. AUTOPULSE IQ-318C supports installation of an optional ACM-series annunciator in the same cabinet. UL and ULC Listed.

AUTOPULSE IQ-318E: Same as AUTOPULSE IQ-318 above, but with 240 V operation.

TR-318: Trim ring for the AUTOPULSE IQ-318 cabinet.

Option Modules

ACPS-610: 6.0 A or 10 A addressable charging power supply.

APS2-6R: Auxiliary Power Supply. Provides up to 6.0 amperes of power for peripheral devices. Includes battery input and transfer relay, and overcurrent protection. Mounts on two of four positions on a CHS-4L or CHS-4 chassis.

FCPS-24S6/-24S8: Remote six-amp and eight-amp power supplies with battery charger.

Compatible Devices, EIA-485 Ports

PRN-6: 80-column printer.

ACM-24AT: ACS annunciator – up to 96 points of annunciation with Alarm or Active LED, Trouble LED, and switch per circuit. Active/Alarm LEDs can be programmed (by powered-up switch selection) by point to be red, green, or yellow; the Trouble LED is always yellow.

AEM-24AT: Same LED and switch capabilities as ACM-24AT, expands the ACM-24AT to 48, 72, or 96 points.

ACM-48A: ACS annunciator – up to 96 points of annunciation with Alarm or Active LED per circuit. Active/Alarm LEDs can be programmed (by powered-up switch selection) in groups of 24 to be red, green, or yellow. Expandable to 96 points with one AEM-48A.

AEM-48A: Same LED capabilities as ACM-48A, expands the ACM-48A to 96 points.

TM-4: Transmitter Module. Includes three reverse-polarity circuits and one municipal box circuit; mount on AUTOPULSE IQ-318 chassis or remotely.

FDU-80: Remote LCD display, 80 characters, with LEDs.

LCD2-80: Terminal mode. 80-character, backlit LCD display. Mounts up to 6000 ft (1828.8 m) from panel. Up to 32 per AUTOPULSE IQ-318.

LDM: Lamp Driver Modules LDM-32, LDM-E32, and LDMR32; remote custom driver modules.

ACM-8R: Remote Relay Module with eight Form-C contacts. Can be located up to 6,000 ft (1828.8 m) from panel on four wires.

UDACT: Universal Digital Alarm Communicator Transmitter, 636 channel.

UDACT-2: Universal Digital Alarm Communicator Transmitter, 636 channel.

Compatible Intelligent Devices

FSI-851: Low-profile FlashScan ionization detector, will replace FSI-751.

FSP-851: Low-profile FlashScan photoelectric detector, will replace FSP-751.

FSP-851T: Low-profile FlashScan photoelectric detector with 135 °F (57 °C) thermal, will replace FSP-751T.

FSP-851R: Remote-test capable photoelectric detector for use with DNR(W) duct detector housings.

FST-851: FlashScan thermal detector 135 °F (57 °C), will replace FST-751.

FST-851R: FlashScan thermal detector 135 °F (57 °C) with rate-of-rise, will replace FST-751R.

FST-851H: FlashScan 190 °F (88 °C) high-temperature thermal detector.

FAPT-851: FlashScan Acclimate Plus low-profile multi-sensor detector, will replace FAPT-751.

FSL-751: FlashScan VIEW laser photo detector.

B224RB: Low-profile relay base.

DNR: InnovairFlex low-flow non-relay duct-detector housing (order FSP-851R separately). Replaces FSD-751PL/FSD-751RPL.

DNRW: Same as above with NEMA-4 rating, watertight.

B224RB: Low-profile relay base.

B224BI: Isolator base for low-profile detectors.

B210LP: Low-profile base. Standard U.S. style. Replaces B710LP.

B501: European-style, 4 in. (102 mm) base.

B200S: Intelligent programmable sounder base, capable of producing a variety of tone patterns including ANSI Temporal 3. Compatible with synchronization protocol.

B200SR: Sounder base, Temporal 3 or Continuous tone.

FMM-1: FlashScan monitor module.

FDM-1: FlashScan dual monitor module.

FZM-1: FlashScan two-wire detector monitor module.

FMM-101: FlashScan miniature monitor module.

FCM-1: FlashScan NAC control module.

FCM-1-REL: FlashScan releasing control module.

FRM-1: FlashScan relay module.

FDRM-1: FlashScan dual monitor/dual relay module.

NBG-12LX: Manual fire alarm station, addressable.

ISO-X: Isolator module.

XP6-C: FlashScan six-circuit supervised control module.

XP6-MA: FlashScan six-zone interface module; connects intelligent alarm system to two-wire conventional detection zone.

XP6-R: FlashScan six-relay (Form-C) control module.

XP10-M: FlashScan ten-input monitor module.

Enclosures, Chassis, and Dress Plates

MARINE-EQ System: Protects equipment in shipboard and waterfront applications.

NFS-LBBR: Battery Box. Required for batteries larger than 26 AH. Red.

SEISKIT-320/B26: Seismic mounting kit. Required for seismic-certified applications with the AUTOPULSE IQ-318 and BB-26. Includes battery bracket for two 26 AH batteries.

SEISKIT-BB25: Seismic mounting kit for the BB-25. Includes battery bracket for two 26 AH batteries.

SEISKIT-LBB: Seismic kit for the NFS-LBB. Includes battery bracket for two 55 AH batteries.

SEISKIT-PS/2/4: Seismic mounting kit for the FCPS-24S6/S8 and CAB-PS1. Includes battery bracket for two 7 AH or 12 AH batteries.

Other Options

VeriFire-TCD: VeriFire Tools CD-ROM. Contains programming software. Includes local panel connection cable. Programming PC requires a serial port connection.

BAT Series: Batteries. AUTOPULSE IQ-318 utilizes two 12 volt, 18 to 200 AH batteries. This series of products replaces the previous PS Series.

IQ-318RB: Replacement CPU. **Note:** Keypad must be removed before shipping old unit out for repair.

IQ-318ERB: Replacement CPU, Export.

Note: For other options including compatibility with retrofit equipment, refer to the panel's installation manual, the SLC manual, and the Device Compatibility Document.

System Specifications

System Capacity

Intelligent Signaling Line Circuits	1
Intelligent detectors.	159
Addressable monitor/control modules	159
Programmable internal hardware and output circuits.	4
Programmable software zones	99
Special programming zones.	14
LCD annunciators per CPU-318/-318E	32
ACS annunciators per CPU-318/-318E.	32 addresses x 64 points

Specifications

Primary input power, **CPU-318 board:** 120 VAC, 50/60 Hz, 5.0 A.
CPU-318E board: 220/240 VAC, 50/60 Hz, 2.5 A.

Total output 24 V power: 6.0 A in alarm.

Note: The power supply has a total of 6.0 A of available power. This is shared by all internal circuits.

Standard notification circuits (4): 1.5 A each.

Four-wire detector power (Resettable regulated 24V power outputs): 1.25 A.

Two non-resettable regulated 24V power outputs:

- 1.25 A.
- 0.50 A.

Non-resettable 5V power: 0.15A.

Battery charger range: 18 AH – 200 AH. Use separate cabinet for batteries over 26 AH.

Float rate: 27.6 V.

Cabinet Specifications

AUTOPULSE IQ-318 cabinet dimensions:

BACKBOX, OUTSIDE: 18.240 in. (463 mm) height,
5.77 in. (147 mm) deep.

WITH DOOR: 18.870 in. (479 mm) wide x 18.469 in. (469 mm) high
x 5.817 in. (148 mm) deep.

BACKBOX, INSIDE: 18.120 in. (460 mm) inner width,
5.175 in. (131 mm) inner depth.

Temperature and Humidity Ranges

This system meets NFPA requirements for operation at 32 – 120 °F (0 – 49 °C) and at a relative humidity 93% ± 2% RH (noncondensing) at 90 °F ± 3 °F (32 °C ± 2 °C). However, the useful life of the system's standby batteries and the electronic components may be adversely affected by extreme temperature ranges and humidity. Therefore, it is recommended that this system and its peripherals be installed in an environment with a normal room temperature of 60 – 80 °F (15 – 27 °C).

Standards

The AUTOPULSE IQ-318 complies with the following UL Standards and NFPA 72 Fire Alarm Systems requirements:

UL 864, 9th Edition.

UL 1076 (Burglary).

LOCAL (Automatic, Manual, Waterflow and Sprinkler Supervisory).

AUXILIARY (Automatic, Manual and Waterflow) (requires 4XTMF).

REMOTE STATION (Automatic, Manual and Waterflow) (requires 4XTMF).

PROPRIETARY (Automatic, Manual and Waterflow). Not applicable for FM.

Agency Listings and Approvals

These listings and approvals apply to the basic AUTOPULSE IQ-318 control panel. In some cases, certain modules may not be listed by certain approval agencies, or listing may be in process. Consult factory for latest listing status.

The AUTOPULSE IQ-318 complies with UL Standards 864, 9th Edition (Fire). It is designed to meet NFPA 72 Local, Auxiliary, Remote Station, and Proprietary (not applicable for FM) Fire System Requirements.

UL Listed S4935

ULC Listed S4935

FM Approved

MEA 128-07-E

California State Fire Marshall 7165-0595:117

FDNY COA#6043

OSHPD OSP-0072-10

City of Chicago

When used with the MARINE-EQ, appropriate seismic bracket, and marine approved devices, these agent releasing control panels are approved by the following agencies:

US Coast Guard. 161.002/A50/0 (Standard 46 CFR)

Ordering Information

Part No.	Description
434957	AUTOPULSE IQ-318 FACP, 120 VAC
434958	AUTOPULSE IQ-318C FACP, 120 VAC (ULC)
434959	AUTOPULSE IQ-318E FACP, 240 VAC

Note: The converted values in this document are provided for dimensional reference only and do not reflect an actual measurement.

ANSUL, AUTOPULSE, and the product names listed in this material are marks and/or registered marks. Unauthorized use is strictly prohibited.